

# ECE ZIP™ Shutter

For Use with Dymax ECE Flood Lamp Systems

- Instructions for Safe Use
- Setup and Operation
- Maintenance
- Ordering Spare Parts and Accessories

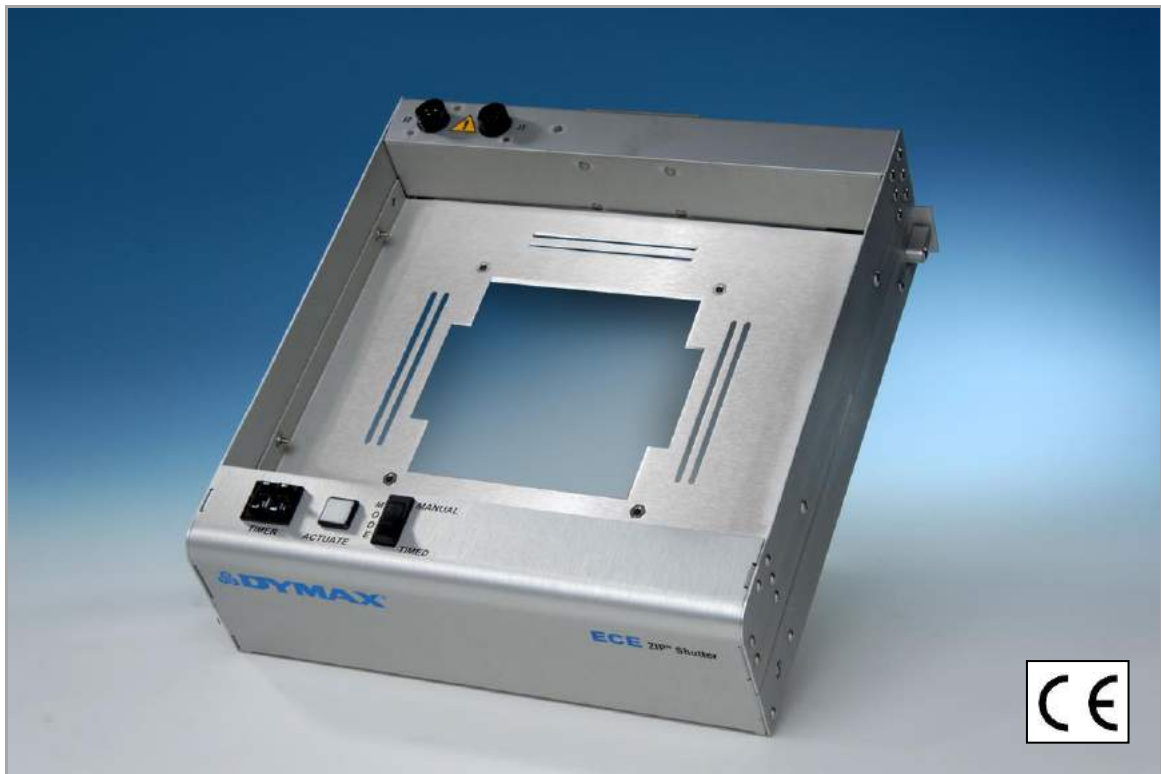

### **About Dymax**

#### **UV/Visible light-curable adhesives. Systems for light curing, fluid dispensing, and fluid packaging.**

Dymax manufactures industrial adhesives, light-curable adhesives, epoxy resins, cyanoacrylates, and activator-cured adhesives. We also manufacture a complete line of manual fluid dispensing systems, automatic fluid dispensing systems, and light-curing systems. Light-curing systems include LED light sources, spot, flood, and conveyor systems designed for compatibility and high performance with Dymax adhesives.

Dymax adhesives and light-curing systems optimize the speed of automated assembly, allow for 100% in-line inspection, and increase throughput. System designs enable stand-alone configuration or integration into your existing assembly line.

Please note that most dispensing and curing system applications are unique. Dymax does not warrant the fitness of the product for the intended application. Any warranty applicable to the product, its application, and use is strictly limited to that contained in the Dymax standard Conditions of Sale. Dymax recommends that any intended application be evaluated and tested by the user to ensure that desired performance criteria are satisfied. Dymax is willing to assist users in their performance testing and evaluation by offering equipment trial rental and leasing programs to assist in such testing and evaluations. Data sheets are available for valve controllers or pressure pots upon request.

# Contents

<b>Introduction</b> .....	<b>4</b>
Introduction to the User Guide .....	4
Where to Get Help .....	4
<b>Safety</b> .....	<b>4</b>
General Safety Considerations .....	4
Specific Safety Considerations.....	5
<b>Product Overview</b> .....	<b>5</b>
Description of the ECE <i>ZIP Shutter</i> .....	5
System Components.....	6
<b>Assembly and Setup</b> .....	<b>7</b>
Unpacking and Inspecting Your Shipment.....	7
Parts Included in the ECE <i>ZIP Shutter</i> (PN 40885).....	7
Installation and System Interconnect.....	8
<b>Operation</b> .....	<b>11</b>
<b>Maintenance</b> .....	<b>12</b>
Check and Adjust Curtain Drive-Belt Tension .....	12
Shutter Curtain Assembly Replacement.....	13
<b>Troubleshooting</b> .....	<b>14</b>
<b>Spare Parts and Accessories</b> .....	<b>15</b>
<b>Specifications</b> .....	<b>16</b>
Systems Specifications (Clear Aperture).....	16
<b>Definition of Terms</b> .....	<b>17</b>
<b>Warranty</b> .....	<b>18</b>
<b>Index</b> .....	<b>19</b>

# Introduction

## Introduction to the User Guide

This guide describes how to assemble, use, and maintain the ECE ZIP™ Shutter safely and efficiently.

## Intended Audience

Dymax prepared this user guide for experienced process engineers, technicians, and manufacturing personnel. If you are new to UV light curing and do not understand the instructions, contact Dymax Application Engineering to answer your questions before using the equipment.

## Where to Get Help

Dymax Customer Support and Application Engineering teams are available in the United States, Monday through Friday, from 8:00 a.m. to 5:30 p.m. Eastern Standard Time. You can also email Dymax at [info@dymax.com](mailto:info@dymax.com). Contact information for additional Dymax locations can be found on the back cover of this user guide.

Additional resources are available to ensure a trouble-free experience with our products:

- Detailed product information on [www.dymax.com](http://www.dymax.com)
- Dymax adhesive Product Data Sheets (PDS) on our website
- Material Safety Data Sheets (MSDS) provided with shipments of Dymax adhesives

## Safety



**WARNING!** *If you use a Dymax shutter without first reading and understanding the information in this user guide, injury can result from exposure to high-intensity light. To reduce the risk of injury, read and ensure you understand the information in this user guide before assembling and operating a Dymax shutter in a UV flood lamp system.*

## General Safety Considerations

All users of Dymax equipment should read and understand this user guide before assembling and using the equipment.

To learn about the safe handling and use of light-curable formulations, obtain and read the MSDS for each product. Dymax includes an MSDS with each adhesive sold. In addition, fluid product MSDS can be requested through our website.

## Specific Safety Considerations

Dymax shutters are designed to maximize operator safety and minimize exposure to UV light. To use the shutter safely, it must be set up and operated in accordance with the instructions in this user guide. Please also read and understand the following safety considerations.



**WARNINGS!** To prevent eye injury, always wear protective goggles when working near a UV light-curing system.

Long-sleeved shirts or a lab coat are recommended to protect the arms and use of UV opaque gloves will protect the hands from UV exposure.

# Product Overview

## Description of the ECE ZIP Shutter

Dymax shutters were developed as auxiliary devices to improve operator safety and to control the dose of curing energy directed onto adhesives in a flood-lamp curing systems. The ECE ZIP Shutter is compatible with Dymax ECE 2000 and ECE 5000 flood lamps. The shutter can be used as an integral part of the Dymax ECE light shield.

Dymax flood lamps use a medium-pressure arc bulb as a source of curing energy. The bulb requires a few minutes to warm up after ignition before it reaches a steady state and needs a few minutes to cool before being able to re-ignite after being turned off. Repeatedly turning the power to the bulb off and on negatively affects its lifetime. With a Dymax shutter installed, the flood lamp may stay on continuously. Objects needing curing may be loaded and unloaded from underneath the shutter when it is closed without exposing parts or operators to UV light. In addition, control of curing times can be achieved by timed shutter operation.

Dymax flood lamp systems are used for a wide variety of applications where a relatively large area of illumination is needed. These applications may be cured using one of two types of systems: the first is with continuous illumination in conveyORIZED curing systems where the dose is defined by the conveyor belt speed. The second type uses a free-standing flood lamp where accurate timing is required. In the second type, the shutter can ensure the proper dose.

## System Components

Figure 1. ECE ZIP Shutter Component Diagram

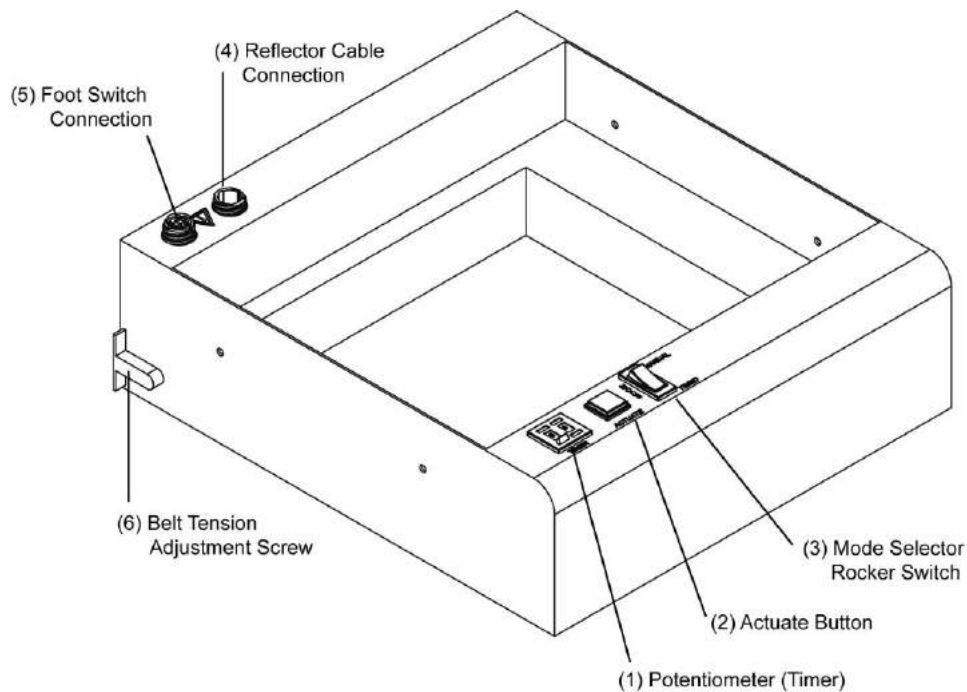

- **Digital Potentiometer (Timer) (1)** - The operator sets the shutter's "open time" using the digital potentiometer (timer) on the control panel. The shutter's "open time" can be set from 1 to 99 seconds.
- **Actuate Button (2)** - Depressing the actuate button activates the gear motor inside the shutter. The unit can also be actuated by foot switch. The foot switch can be connected to the foot switch connection (5) on top of the rear panel.
- **Mode Selector Rocker Switch (3)** - There are two operation modes available: manual and timed. The mode selector rocker switch is used to select the mode of operation.
- **Mounting Plates/Adapter Plates** - The ZIP Shutter includes two mounting plates for various reflector housings. The first has a clear aperture of 5" x 5" and should be used with the ECE 5000. The second has a clear aperture of 8" x 8" for use with an ECE 2000. The ZIP Shutter has a clear aperture, therefore there is no distraction of the light flow when the shutter is open.
- **Reflector Cable Connection (4)** - The power (24V) to the ZIP Shutter comes directly from the flood lamp's power supply, which is connected through this receptacle on top of the shutter's rear panel.
- **Belt Tension Adjustment Screw (6)** - Used to tighten the curtain drive belt.

# Assembly and Setup

## Unpacking and Inspecting Your Shipment

When your ECE Zip Shutter arrives, inspect any boxes for damage and notify the shipper immediately of box damage.

Open each box and check for equipment damage. If parts are damaged, notify the shipper and submit a claim for the damaged parts. Contact Dymax so that new parts can be shipped to you immediately.

Check that the parts included in your order match those listed below. If parts are missing, contact your local Dymax representative or Dymax Customer Support to resolve the problem.

## Parts Included in the ECE ZIP Shutter (PN 40885)

- **ECE ZIP Shutter** (1)
- **Dymax Shutters for ECE Systems User Guide** (2)
- **Interconnect Cable** (3) - Connects the Shutter to the Flood Lamp
- **Foot Switch** (4)
- **Brackets** (5) - Connect the ECE Shutter to the ECE Light Shield
- **Tools & Hardware** - M4 x 25 mm Screws (6), M4 x 8 mm Screws (7), & Hex Wrench (8)
- **Mounting Plates** - for the ECE 2000 (9) & ECE 5000 (10)
- **Plenum Assembly for the ECE 5000** (11)

Figure 2. ECE Zip Shutter Components

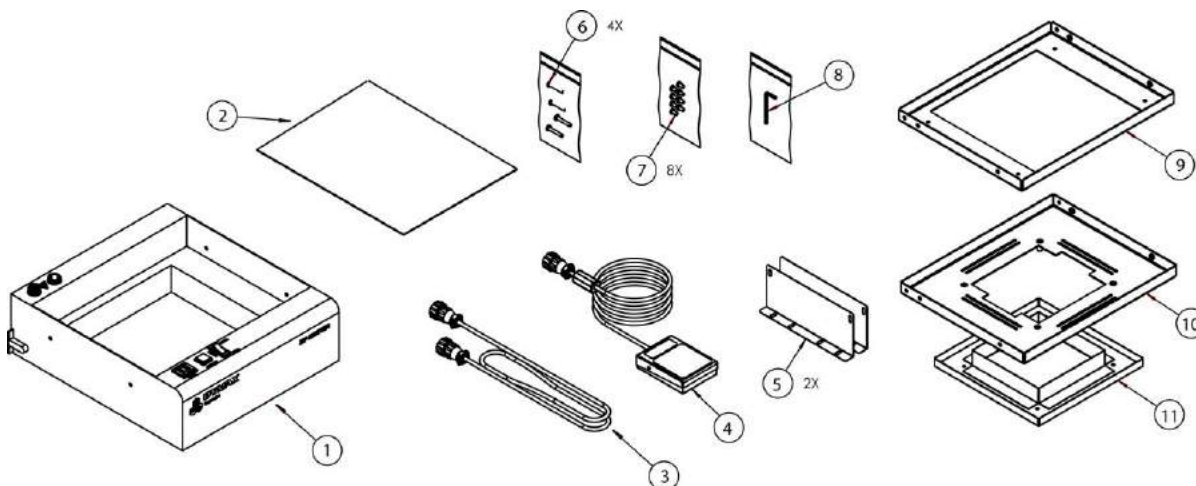

## Installation and System Interconnect

**NOTE:** Setup of the ECE flood lamps is covered in the ECE-series user guides. Refer to MAN045 – ECE-Series Flood Lamp User Guide.

### ECE 5000 Flood Lamp

1. Remove the Mounting Plate from the ZIP Shutter by removing the four M4 x 8 mm flat head screws (Figure 3).

**Figure 3. ECE ZIP Shutter with Mounting Plate Installed**

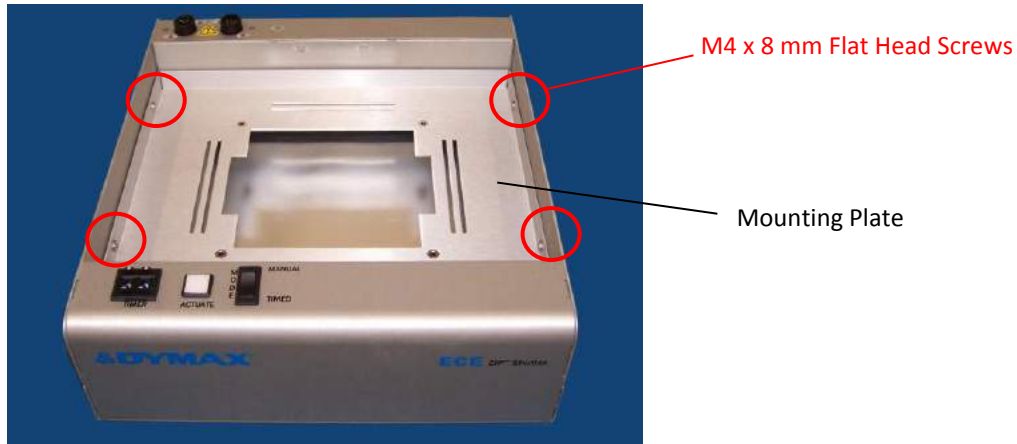

**NOTE:** If the ZIP Shutter and the Lamp Assembly are NOT installed into a Light Shield, the Glass Containment Shield must be installed.

2. Install the Glass Shield (if applicable). Follow the instructions below:
  - Remove the Filler Plate from the Reflector Housing and install the glass on the Reflector Housing edges.
  - Replace the Filler Plate and screws securely.

**Figure 4. Reflector Housing with Filler Plate**

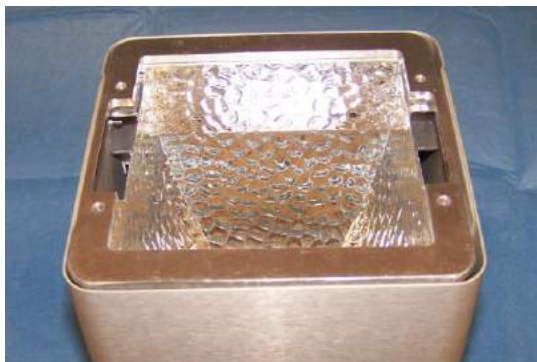

**Figure 5. Reflector Housing, Filler Plate Removed**

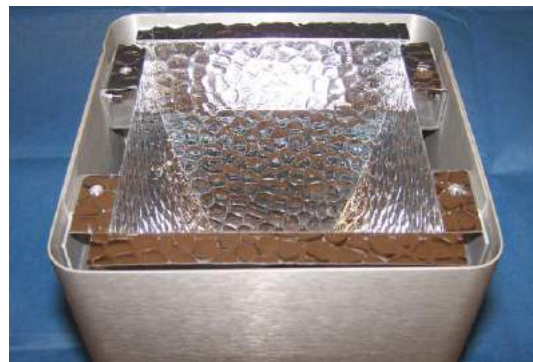

3. Place the Mounting Plate onto the Reflector Housing (Figure 6) and then place the Air Plenum on top of the Mounting Plate (Figure 7). Attach all three components together with four new M4 x 25 mm screws.



**Figure 6. Attach Mounting Plate to Reflector Housing**

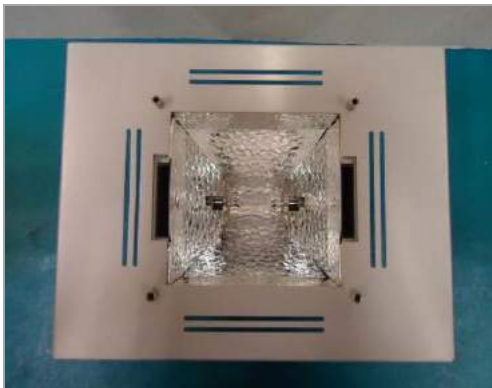

**Figure 7. Attach Air Plenum to Filler Plate/Reflector Assembly**



- 4. Install the Lamp Housing Assembly into the ZIP Shutter and attach it with four M4 x 8 screws (Figure 9).

**NOTE:** One side of the Filler Plate has a third screw hole (Figure 8). When in the correct position, this screw hole will be at the rear of the Shutter.

**Figure 8. Lamp Housing Assembly**



Third Screw Hole

**Figure 9. ECE 5000 Lamp Housing Assembly Installed with M4 x 8 Screws**

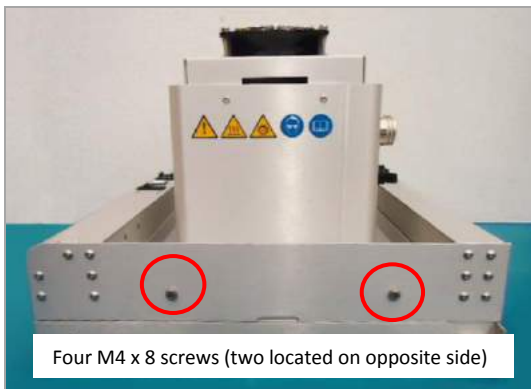

Four M4 x 8 screws (two located on opposite side)

## ECE 2000 Flood Lamps

**NOTE:** If the ZIP Shutter and Lamp Assembly are NOT installed into a Light Shield, the Glass Containment Shield must be installed.

1. Install the Glass Shield (if applicable) (Figure 10).
2. Install the ECE 2000 Mounting Plate on the base of the ECE 2000 Lamp Housing (Figure 11) by installing the M4 x 8 mm screws.
3. Install the Glass Shield (if applicable).

**Figure 10. Reflector Housing with Glass Shield Installed**



**Figure 11. Lamp Housing with Mounting Plates Installed**



4. Install the Lamp Housing Assembly into the ZIP™ Shutter and attach it with four M4 x 8 mm screws (Figure 13).

**NOTE:** One side of the Mounting Plate has a third screw hole (Figure 12). When in the correct position, this screw hole will be at the rear of the Shutter.

**Figure 12. Lamp Housing Assembly**



Third Screw Hole

**Figure 13. ECE 2000 Lamp Housing Assembly Installed with M4 x 8 Screws**

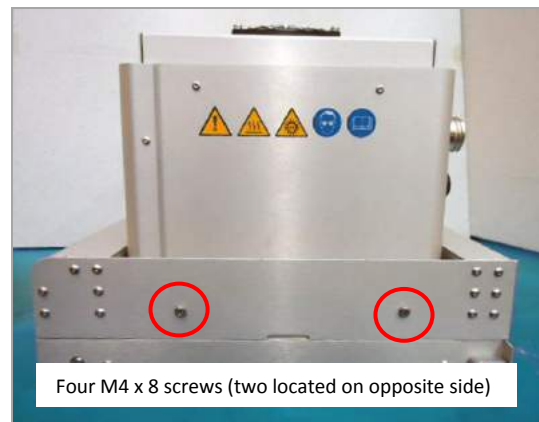

Four M4 x 8 screws (two located on opposite side)

## ECE ZIP Shutter Electrical Interconnect

Figure 14. ECE ZIP Shutter Electrical Interconnect Diagram

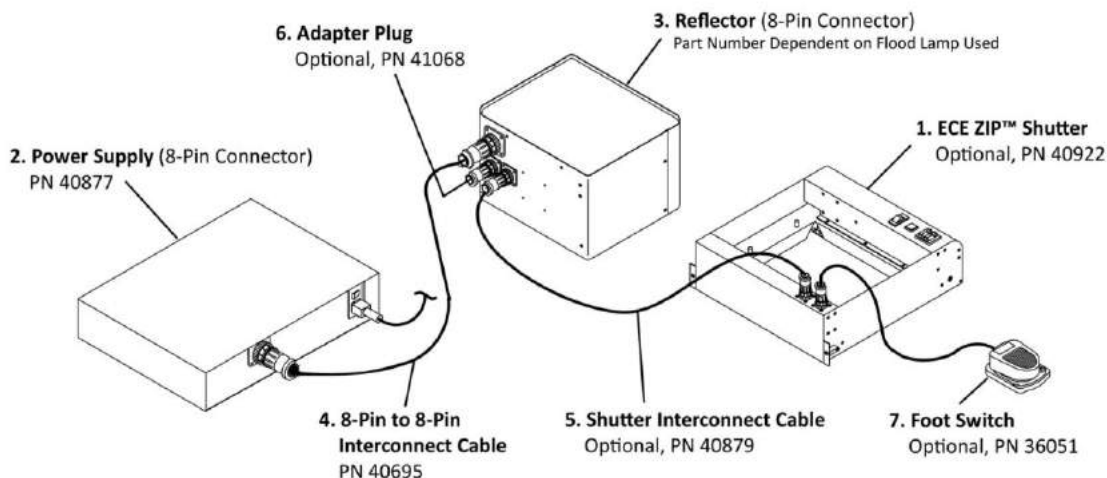

1. Connect Shielded Cable (4) from J2 on rear of Power Supply (2) to J3 on rear of Reflector Housing (3).
2. Connect Cable (5) from J4 on rear of Reflector (3) to 8-Pin Connector on rear of Shutter (1).
3. Connect Plug (6) into J5 on rear of Reflector (3).

**NOTE:** Shutter will not operate unless the Adapter Plug is installed.

4. Install Foot Pedal to 4-Pin Connector on rear of Shutter (7).
5. Connect Power Cord to J1 on rear of Power Supply (2).

## Operation

1. Check that the ECE ZIP Shutter is in the closed position and load parts to be cured on the Light Shield work surface (preferably in line with the center of the shutter).

**NOTE:** The ECE ZIP Shutter incorporates a safety circuit that if the Light Shield door is opened during an exposure cycle, it will automatically close the shutter curtain and shut the lamp off.

2. Adjust the distance from the bottom plane of the ECE ZIP Shutter to the surface to be cured.
3. Close the Light Shield Door once the parts to be cured are loaded.
4. With the Light Shield Door closed, set the exposure (ECE ZIP Shutter "Open Time") by adjusting +/- the Timer located next to the Actuate Button on the Front Panel.
5. Open the ECE ZIP Shutter using the most convenient method for you by using Actuate Button or Foot Switch.

**NOTE:** The ECE ZIP Shutter will close automatically in timed mode or will stay open until you release the Foot Switch or Actuator Button in manual mode

6. Close the ECE *ZIP Shutter* to end the cycle.

## Maintenance

### Check and Adjust Curtain Drive-Belt Tension

**Figure 15. Belt Tension Adjustment**

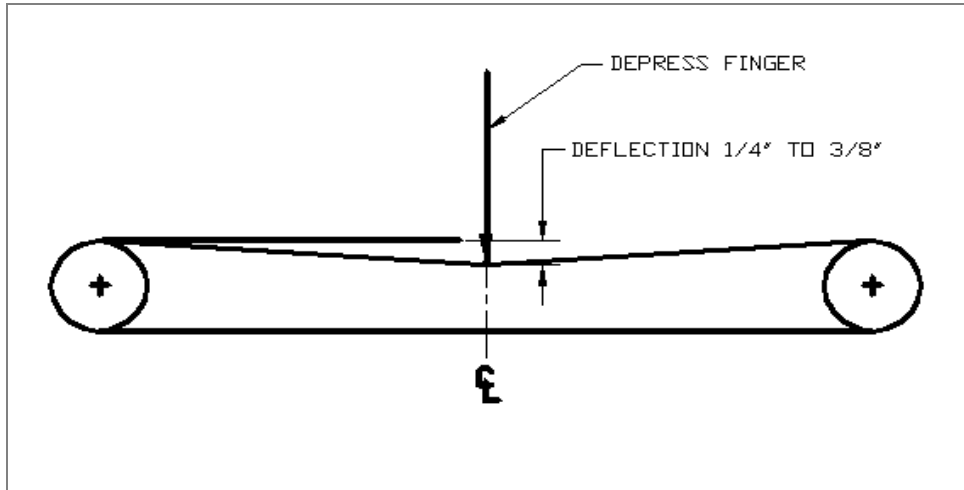

Dymax recommends that the Curtain Drive-Belt's tension be checked at least once every three months. Follow the instructions below to check the tension.

1. Turn off and disconnect the Lamp Reflector Housing from the external AC source.
2. Remove the *ZIP Shutter* from the Flood Lamp Reflector Housing and place it on the bench, bottom-side up.
3. Remove the screws that attach the *ZIP Shutter's* bottom panel.
4. Very lightly press in the center of the Curtain Drive Belt with a finger; the Belt should deflect no more than  $\frac{1}{4}$ " to  $\frac{3}{8}$ ".
5. If deflection exceeds this value, tighten the Curtain Drive Belt by adjusting the Tension Screw in the back of the *ZIP Shutter*.

**NOTE:** Make sure that both belts are tightened equally.

6. Replace the bottom cover and secure it with its screws.
7. Place the *ZIP Shutter* back on the Flood Lamp Reflector Housing and re-position it.
8. Reconnect the cables and plug the AC cord into wall socket.

## Shutter Curtain Assembly Replacement

Dymax recommends that you check the *ZIP Shutter* curtain for wear each time you change the lamp. If it shows any signs of wear, replace it. Additional curtain assembly replacements can be purchased through Dymax Customer Service.



**CAUTION! SHARP EDGES!** *The edge of the stainless steel curtain is extremely sharp. To prevent injuries, always wear gloves that are resistant to cuts when handling or installing equipment. We recommend, at a minimum, CE Cut Level 5 gloves (included with kit).*

Figure 16. ZIP™ Curtain Assembly Diagram

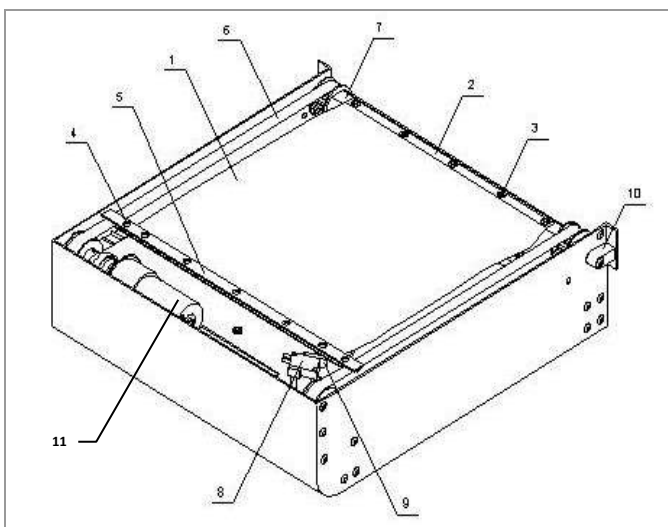

#	Description
1	Curtain
2	Roller Bar
3	Screws (5)
4	Side Screws (2)
5	Clamp Bar
6	Belts
7	Roller and Pulley
8	Limit Switch
9	Limit Switch Standoff
10	Belt Tension
11	Belt Drive Motor

1. Remove the Flood Lamp Reflector Assembly from the ECE *ZIP Shutter* and flip the Shutter onto its top.
2. Remove the bottom cover of the ECE *ZIP Shutter* to expose the inside Roller (7) and Belt Drive Motor.
3. Manually unroll the Curtain (1) until the Curtain (1) reaches Large Limit Switch (8).
4. Loosen the Belt (6) tension by unscrewing the rear screws.
5. Remove the old Curtain (1) by removing the five screws (3) on the Roller (7) and loosening the two Side Screws (4) on the Clamp Bar (5) and slide curtain off Belts (6).
6. Attach the new Curtain (1) to the Roller (7) and Roller Bar (2) with the 6-32 screw (3) previously removed from the Roller.
7. Stretch the new Curtain (1) toward front of *ZIP Shutter*.
8. Slide the Clamp Bar (5) onto the Belt (6) where the Curtain is fully outstretched. The Curtain should be stretched short of front Limit Switch (8).
9. Tighten the end screws 4-40 (4).
10. Manually roll up the Curtain until the Curtain reaches rear Limit Switch (8). If the Clamp Bar (5) bows, loosen the screws (4) and allow the Clamp Bar to find its natural straightness and retighten.
11. Replace the *ZIP Shutter's* bottom cover.
12. Set-up the *ZIP Shutter* according to the *ZIP Shutter* directions. Tighten the Belt Tension (10) as needed to improve Belt performance.

# Troubleshooting

**CAUTION:** Only qualified maintenance personnel should attempt the following procedures.

Problem	Possible Cause	Testing	Corrective Action
The shutter curtain does not open or close smoothly	One of the tension screws is not tight enough	All functions of the <i>ZIP Shutter</i> operate properly	Adjust the curtain tension
The shutter's motor continuously runs	One of the Limit Switches is not engaging properly	All functions of the <i>ZIP Shutter</i> operate properly	Adjust the micro-switch activating blade
The shutter will not operate	No power at shutter	Verify the supply voltage being delivered to the shutter. Test the voltage at pins 1 & 2 of the 8-pin connector (24 VDC)	Check and replace the wiring if the light source is operational but the <i>ZIP Shutter</i> is not. If a problem occurs within the light source, consult the user guide
	The plug (38317 or 38318) is not installed in J5 of the reflector housing	All functions of the <i>ZIP Shutter</i> operate properly	Install the plug as described in the installation instructions

# Spare Parts and Accessories

Item	Part Number
<b>Hardware</b>	
M4x8 Pan Head Screws, Qty. 8	38611
M4x25 Pan Head Screws , Qty. 4	39586
M3x10 Flat Head Screws , Qty. 4	40013
<b>Replacement Parts</b>	
Clutch	39396
Motor	39395
Timer Board, 0-99 Seconds	40315
Stainless Steel Curtain Upgrade Kit (Cloth to SS)	41097
Stainless Steel Curtain Replacement Kit (SS to SS)	41146
<b>Cables, Foot Switches, &amp; Plugs</b>	
Cable, Reflector Housing to Shutter, ECE Series	40879
Standard Foot Switch	36051
Foot Switch with Extended Cable	38992
Plug, Standard Adapter	41068

# Specifications

## Systems Specifications (Clear Aperture)

Property	Specification
	<b>40885</b> ZIP™ Shutter for ECE-Series Flood Lamps
<b>Operating Voltage</b>	24 VDC (Supplied by the Dymax ECE Power Supply)
<b>Exposure Time</b>	Digital Setting - From 1 to 99 Seconds
<b>Aperture</b>	6" x 8" [15.24 cm x 20.32 cm]
<b>Operation Modes</b>	Timed/Manual
<b>Dimensions</b>	12.5" x 12.9" x 3.8" [31.8 cm x 32.8 cm x 9.7 cm]
<b>Weight</b>	5.45 lbs. [2.47 kg]

Figure 17. ECE ZIP™ Shutter Dimensions

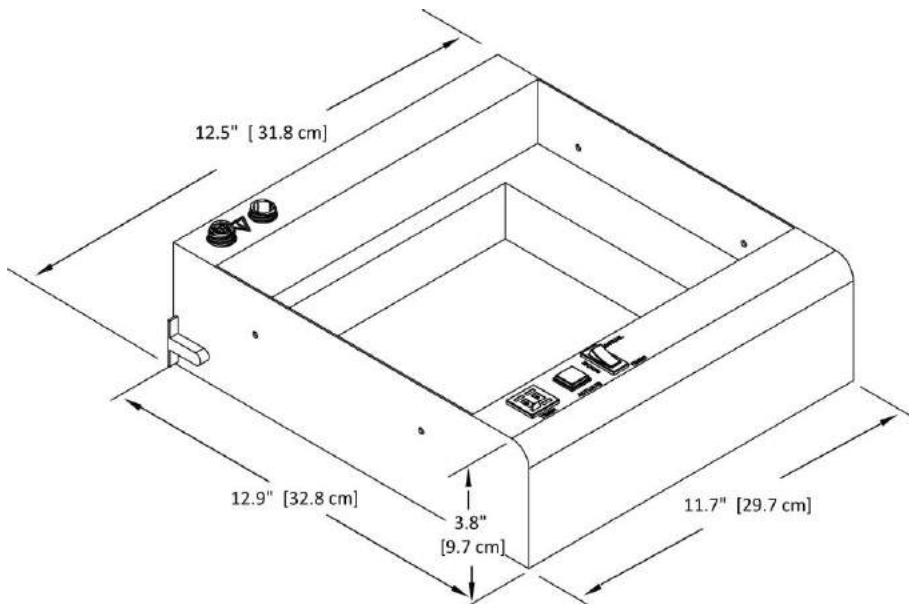



# Definition of Terms

**UV Curing Light Source** - a reflector housing and a power supply furnished with an appropriate bulb (burner) for generating light energy of required spectra and intensity.

**Flood Lamp System** - a set of components arranged to generate, collect, condition, and direct UV radiant energy to perform curing of engineering adhesives, coatings, and inks in a safe and controlled process. It includes a lamp housing and power supply and may also include a shutter, workstation, UV enclosure, Dymax light shield, and accessories.

**Lamp** - light source (bulb or burner) generating ultraviolet, visible, or infrared radiant energy from burning matter stimulated by electrical power. A bulb or burner is usually placed into a reflector to increase light source efficiency by collecting and directing radiant energy of selected spectra for a specific curing process.

**Intensity** - a measure of light energy over the unit of surface area (usually at a specified working distance from the bottom of a reflector housing) in  $W/cm^2$  or  $mW/cm^2$ . For the UV portion of light, this measure is often called in literature “irradiance”, i.e. radiant energy arriving at a point on a surface per unit area.

**Brightness, also known as Luminance** - description of energy in the visible region of the spectrum (approximately from 400 to 700 nm) and recorded in photometric units. “Intensity” (see below) of visible light energy is called luminance.

**Luminance** - luminous flux (energy of visible light) incident per unit area, and measured in **Lx** (lux) or **Lumen/cm<sup>2</sup>**.

**Ultraviolet (UV)** - the invisible region of the spectrum just beyond the violet end of the visible region. UV is divided into three spectral parts:

1. **Ultraviolet A (UV-A)** - UV of long wavelength from within approximately 400 to 320 nm of the spectral band (4000 to 3200 $\oplus$ ) - predominately produced by Dymax Flood Lamps.
2. **Ultraviolet B (UV-B)** - UV of medium wavelength from within approximately 320 to 280 nm - Dymax Flood Lamps produce some amount of their energy within this bandwidth.
3. **Ultraviolet C (UV-C)** - UV of short wavelength below 280 nm (we say from 280 to 200 nm) – a large amount of this energy is present in the sunlight.

**Dose** - is irradiance integrated over time, or Irradiance ( $W/cm^2$ ) x Time (s) = Dose (Joules/cm<sup>2</sup>). Note: Watt is the power that gives rise to the production of energy at the rate of 1-joule (J) per second (s).

As irradiance can be a far more significant factor in the efficiency of curing adhesives and other UV-curable materials, the dose and spectral response can also be substantial contributors to the quality cure performance.

**OSHA 1910.145:** “Regulation of Accident prevention Signs and Tags” defines the following headers as:

- **WARNING** – is used when there is a hazardous situation that has some probability of severe injury.
- **CAUTION** - is used to indicate a hazardous situation that may result in minor or moderate injury.
- **NOTICE** - is used to convey a message related directly or indirectly to the safety of personnel, or protection of property.

# Warranty

From date of purchase, Dymax Corporation offers a one-year warranty against defects in material and workmanship on all system components with proof of purchase and purchase date. Unauthorized repair, modification, or improper use of equipment may void your warranty benefits. The use of aftermarket replacement parts not supplied or approved by Dymax Corporation, will void any effective warranties and may result in damage to the equipment.

***IMPORTANT NOTE: DYMAX CORPORATION RESERVES THE RIGHT TO INVALIDATE ANY WARRANTIES, EXPRESSED OR IMPLIED, DUE TO ANY REPAIRS PERFORMED OR ATTEMPTED ON DYMAX EQUIPMENT WITHOUT WRITTEN AUTHORIZATION FROM DYMAX. THOSE CORRECTIVE ACTIONS LISTED ABOVE ARE LIMITED TO THIS AUTHORIZATION.***

# Index

Adjust Curtain Drive Belt Tension, 12

Assembly and Setup, 7

Contact Information, 4

Definition of Terms, 17

Glossary, 17

Help, 4

Installation, 8

Maintenance, 12

Operation, 11

Optional Equipment, 15

Parts Included, 7

Product Overview, 5

Safety, 4

Spare Parts and Accessories, 15

Specifications, 16

Support, 4

System Components, 6

System Interconnect, 8

Troubleshooting, 14

Unpacking, 7

Warranty, 18

Zip Shutter Curtain Replacement, 13



© 2013-2016 Dymax Corporation. All rights reserved. All trademarks in this guide, except where noted, are the property of, or used under license by Dymax Corporation, U.S.A.

**Please note that most dispensing and curing system applications are unique.** Dymax does not warrant the fitness of the product for the intended application. Any warranty applicable to the product, its application and use is strictly limited to that contained in Dymax's standard Conditions of Sale. Dymax recommends that any intended application be evaluated and tested by the user to insure that desired performance criteria are satisfied. Dymax is willing to assist users in their performance testing and evaluation by offering equipment trial rental and leasing programs to assist in such testing and evaluations. Data sheets are available for valve controllers or pressure pots upon request.  
PN40812 MAN051 8/2/2016

---

**Dymax Corporation**  
860.482.1010 | [info@dymax.com](mailto:info@dymax.com) | [www.dymax.com](http://www.dymax.com)

**Dymax Europe GmbH**  
+49 (0) 611.962.7900 | [info\\_de@dymax.com](mailto:info_de@dymax.com) | [www.dymax.de](http://www.dymax.de)

**Dymax Engineering Adhesives Ireland Ltd.**  
+353.1.231.4696 | [info\\_ie@dymax.com](mailto:info_ie@dymax.com) | [www.dymax.ie](http://www.dymax.ie)

**Dymax Oligomers & Coatings**  
860.626.7006 | [info\\_oc@dymax.com](mailto:info_oc@dymax.com) | [www.dymax-oc.com](http://www.dymax-oc.com)

**Dymax UV Adhesives & Equipment (Shanghai) Co. Ltd.**  
+86.21.37285759 | [dymaxasia@dymax.com](mailto:dymaxasia@dymax.com) | [www.dymax.com.cn](http://www.dymax.com.cn)

**Dymax UV Adhesives & Equipment (Shenzhen) Co. Ltd.**  
+86.755.83485759 | [dymaxasia@dymax.com](mailto:dymaxasia@dymax.com) | [www.dymax.com.cn](http://www.dymax.com.cn)

**Dymax Asia (H.K.) Limited**  
+852.2460.7038 | [dymaxasia@dymax.com](mailto:dymaxasia@dymax.com) | [www.dymax.com.cn](http://www.dymax.com.cn)

**Dymax Asia Pacific Pte. Ltd.**  
+65.6752.2887 | [info\\_ap@dymax.com](mailto:info_ap@dymax.com) | [www.dymax-ap.com](http://www.dymax-ap.com)

**Dymax Korea LLC**  
+82.2.784.3434 | [info\\_kr@dymax.com](mailto:info_kr@dymax.com) | [www.dymax.com/kr](http://www.dymax.com/kr)